

BERT FRANK

RIDDLE PENDANT LIGHT

MAINTENANCE

- Lacquered brass should be wiped with a soft duster.
- Coloured parts can be wiped with a dry cloth.

TECHNICAL

- 1 x G9 LED bulb

www.bertfrank.co.uk
+44 (0)207 164 6482

INSTALLATION

- 1**
- Feed electrical cable from ceiling through the wiring exit hole in mounting plate. Screw plate to ceiling.
 - This lamp is **Class 2** and uses **2 Core Double Insulated flex**. It does not matter which wire is connected to the positive main feed.

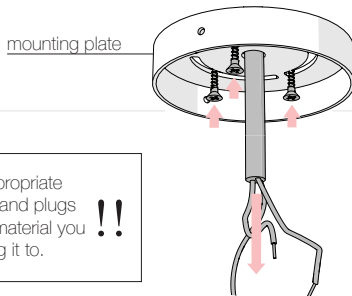

!!! Use appropriate screws and plugs for the material you are fixing it to. !!!

- 2**
- Ensure the pendant is at the desired drop height by adjusting flex length.
 - This is done by loosening the cord grip on the underside of the ceiling cover, adjusting flex length and then tightening the cord grip to lock in place.



- 3**
- Make electrical connection.
 - Connector block not supplied but ensure a suitable type is used.

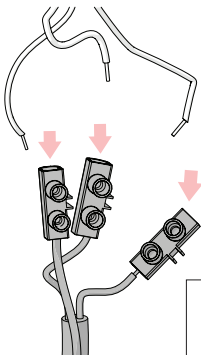

!!! Ensure this is done by a qualified electrician. !!!

- 4**
- Screw the ceiling cover to mounting plate with 3 x screws on side of cover.

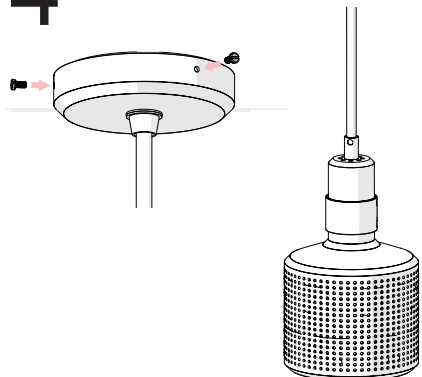

This product is only suitable for connection to the native power supply to which the unit was specifically manufactured. It is for indoor use only, and not suitable for a bathroom location.

If the Class II, double insulated symbol is on the lamp, it does not require an Earth, and Live or Neutral must not be connected to Earth. If there is no such symbol, then the lamp must be Earthed.

Never fit bulbs of a higher wattage than those specified on the label, as these may cause overheating and damage the fitting.

If the mains cable becomes damaged it must only be replaced by a technically competent, qualified person.

Allow 10 minutes to cool before replacing, adjusting or cleaning. Clean with a dry cloth only. Do not use liquid or abrasive cleaners.

If you are in any doubt about your competence please consult a qualified electrician.

If any modification is made it will invalidate the warranty and may render the product unsafe.
